

Thank you for selecting American-Standard - the benchmark of fine quality for over 100 years.  
To ensure that your installation proceeds smoothly--please read these instructions carefully before you begin.

*American Standard*

**7** Maintenance & Repair

**Repairing**

\* When you repair the faucet, you need to shut off water supply.

**Cleaning the surface of faucet**

- \* Rinse the product with clean water.
- \* Dry with soft cotton flannel cloth.
- \* Do not clean the product with acid, polish, abrasives, harsh cleaners, or cloth with a harsh surface as these products may damage the finish.

**8** Trouble Shooting

Trouble	Checkpoint	Contents	Action
Poor flow rate	Supply valve	Check valve position.	Open it to full valve.
Leakage	Cartridge seals	Check cartridge installation.	When seal is damaged, replace it with new one.
	Pipe connection	Check the connection	Check the Vinyl Tape and Wind it up sufficiently.

**9** Term of Guarantee

\* One year for "O" rings or washers. Five years for Chrome plate Body of tap or faulty workmanship  
Lifetime drip free warranty on Cartridge.

- \* Except:
- Trouble caused by disasters or user' s carelessness.
  - If leakage is caused by connection problem with 3rd party products or non approved parts.



Attention Installer:  
Leave this information with the customer after installation is complete.

*American Standard*

A-6506-10  
SAGA Mono Tap

**Installation & Operation Instruction**

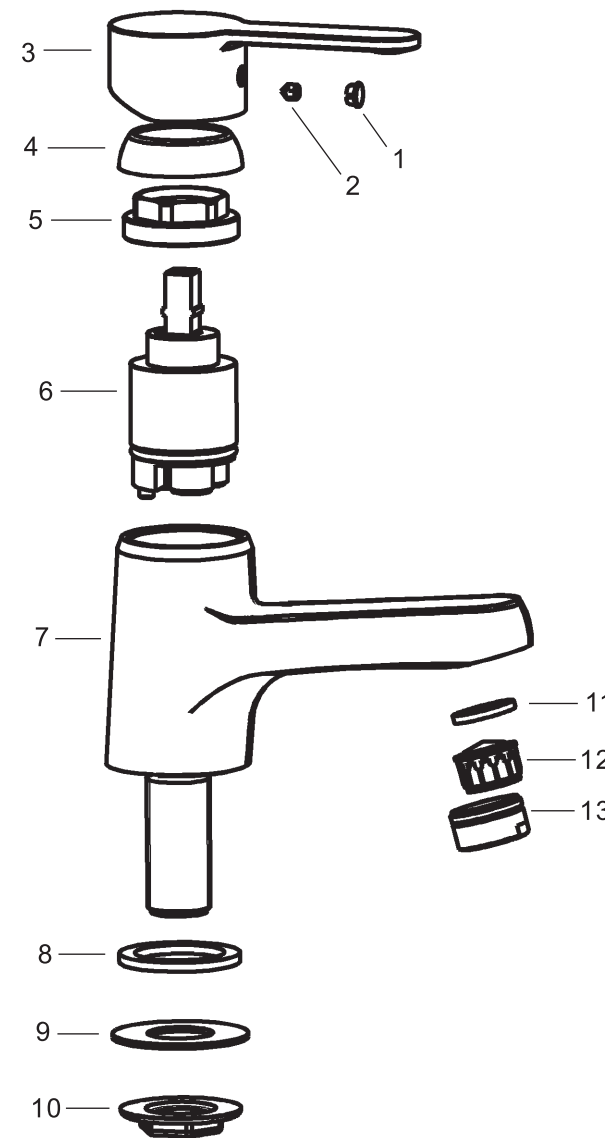
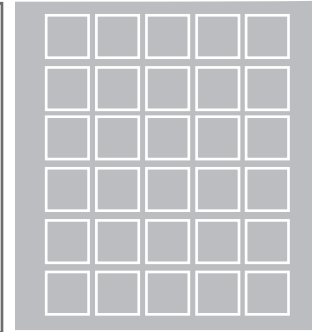
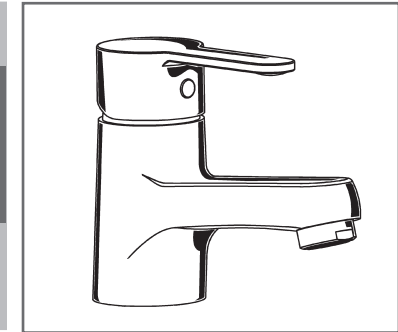

PARTS LIST		
No.	Part Name	Q'ty
1	Index Button	1
2	Screw	1
3	Handle	1
4	Cap	1
5	Nut	1
6	Cartridge	1
7	Body	1
8	Shower	1
9	Shower	1
10	Nut	1
11	Shower	1
12	Aerator	1
13	Aerator Cover	1

## 1 Note

\* Remove all impurities in pipes before beginning.

### \* Conditions for use

\* Recommended water pressure condition: 0.1Mpa~0.5Mpa

\* Environment Temperature: 1~55°C

\* Steam is not allowed to use

\* When in the process of installation, grab the whole body. Do not grab handle only.

## 2 DIMENSION

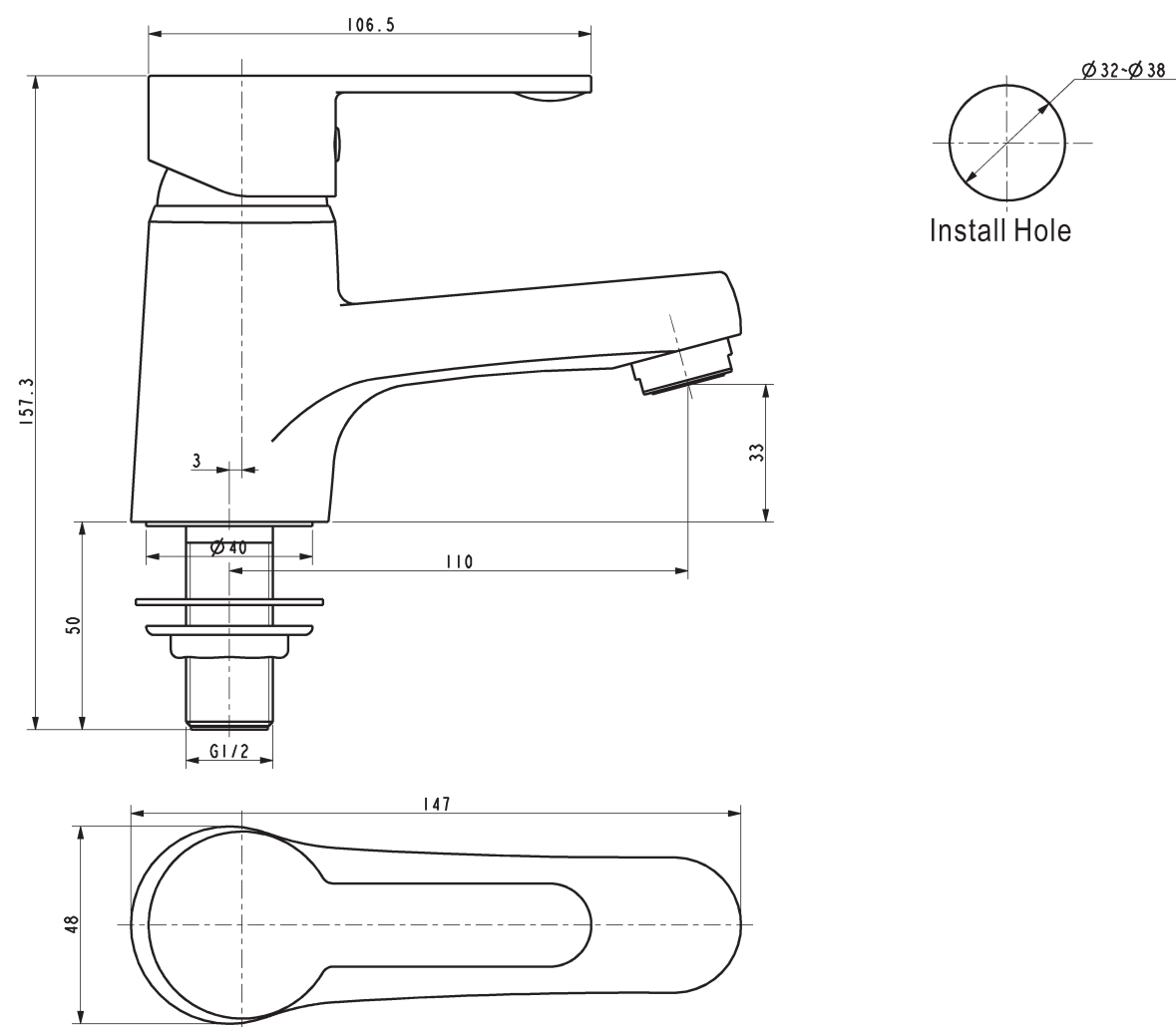

## 3 Install

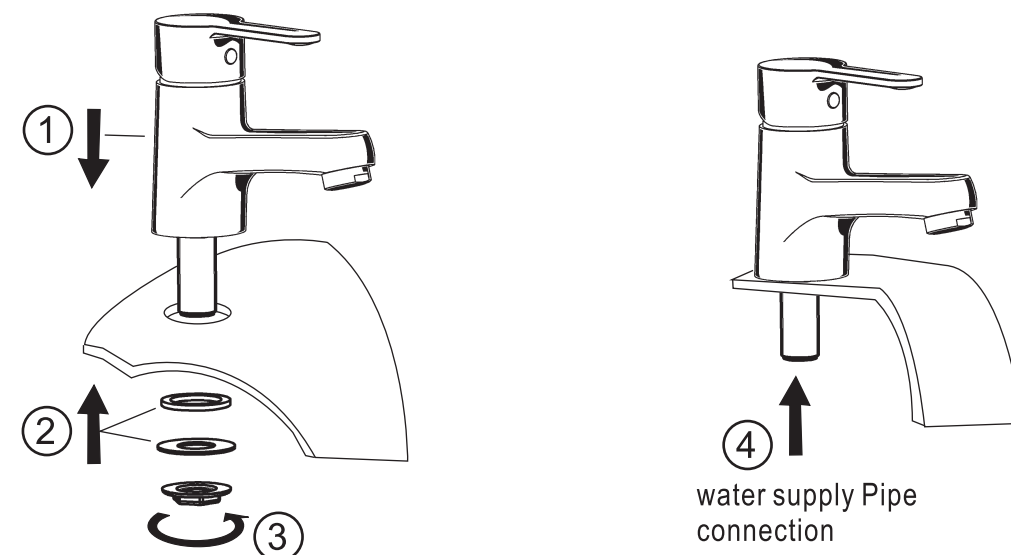

## 4 Usage

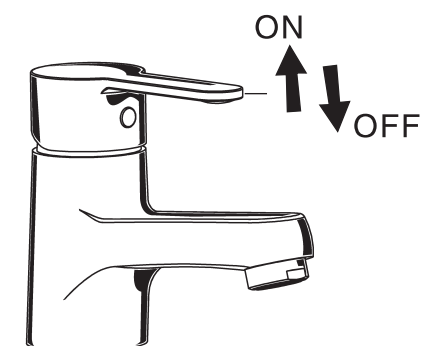

## 5 Test

- \* Move handle down into "off" position. Turn on supply angle valve to check all connections for leak.
- \* Operate handle up and down, left and right to flush water lines thoroughly.

## 6 Maintenance

If you want to change the parts or clean the inner of faucet, please follow the steps in below to remove the parts, then proceed the next steps.

